

CD Radio Cassette-Corder

Operating Instructions

***CFD-CD777S
CFD-CD777L***

Warning

To prevent fire or shock hazard, do not expose the player to rain or moisture.

To avoid electrical shock, do not open the cabinet. Refer servicing to qualified personnel only.

Warning

Do not install the appliance in a confined space, such as a bookcase or built-in cabinet.

The FUNCTION selector is located at the front.

When you turn on the player, the OPR/BATT indicator lights up.

Table of contents

Basic Operations

- 4 Playing a CD
 - 6 Listening to the radio
 - 8 Playing a tape
 - 10 Recording on a tape
 - 12 Dubbing
-

The CD Player

- 14 Using the display
- 15 Locating a specific track
- 16 Playing tracks repeatedly (Repeat Play)
- 17 Creating your own program (Program Play)

The Tape Player

- 19 Recording through a microphone/Using as a PA system

Setting Up

- 20 Hooking up the system
- 23 Connecting optional components
- 24 Adjusting the audio emphasis (DYNAMIC SOUND SYSTEM)

Additional Information

- 25 Precautions
- 27 Troubleshooting
- 29 Maintenance
- 30 Specifications

Back cover

Index

Playing a CD

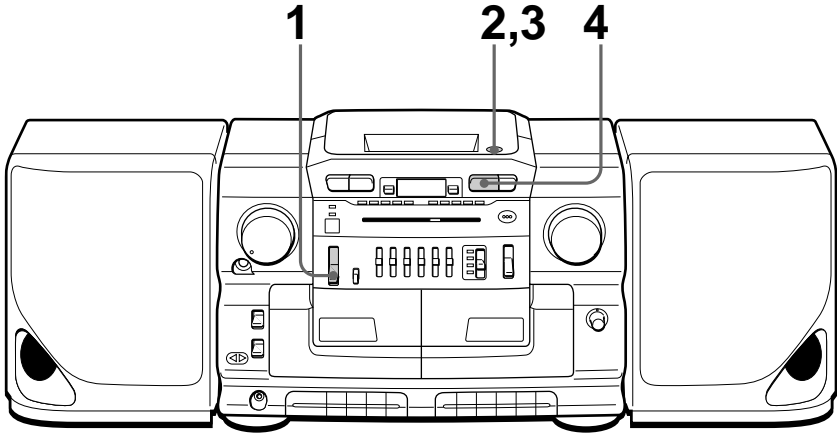

For hookup instructions, see pages 20 – 22.

1

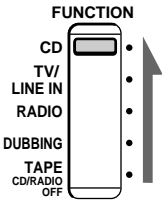

Set FUNCTION to CD.

2

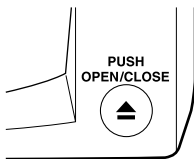

Press ▲ PUSH OPEN/CLOSE down to open the lid of the CD compartment and place a CD on the CD compartment.

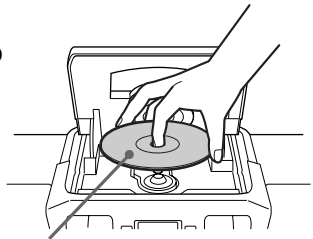

With the label side up

3

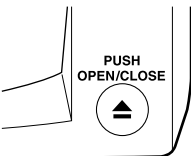

Close the lid of the CD compartment.

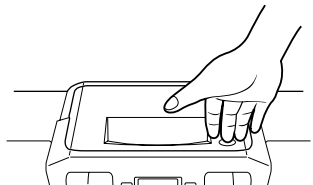

4



Press ►|| (► on the remote).

The player plays all the tracks once.

Display

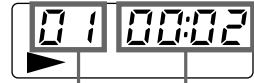

Track number Playing time

Use these buttons for additional operations

FUNCTION ◀◀, ▶▶ ►|| ▲ PUSH OPEN/CLOSE

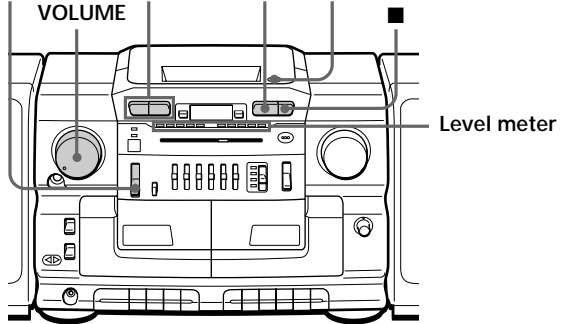

Tip

During operation, the level meter shows the frequency level of the sound.

Adjusting the volume will not affect the level meter.

To	Do this
adjust the volume	Turn VOLUME.
stop playback	Press ■
pause playback	Press ► . (on the remote, press) Press the button again to resume play after pause.
go to the next track	Press ▶▶
go back to the previous track	Press ◀◀
remove the CD	Press ▲ PUSH OPEN/CLOSE.
turn off the player	Set FUNCTION to TAPE • CD/RADIO OFF.

Listening to the radio

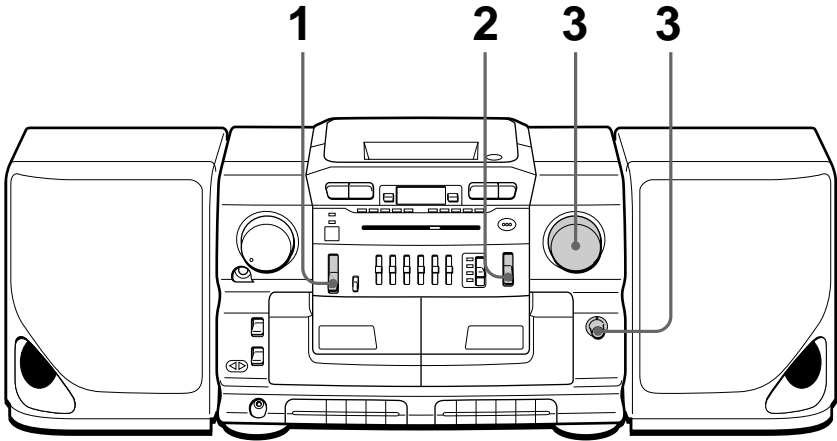

For hookup instructions, see pages 20 – 22.

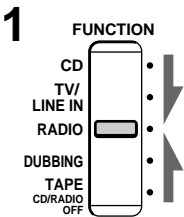

Set **FUNCTION** to **RADIO**.

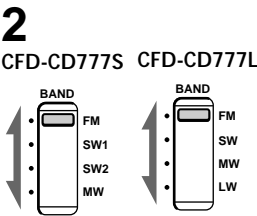

Set **BAND** to select the band you want.

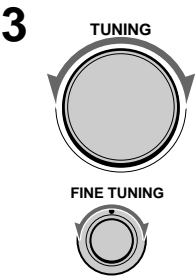

Turn **TUNING** to tune in the station you want.

For better SW reception, use **FINE TUNING**.

Use these buttons for additional operations

FUNCTION VOLUME Level meter

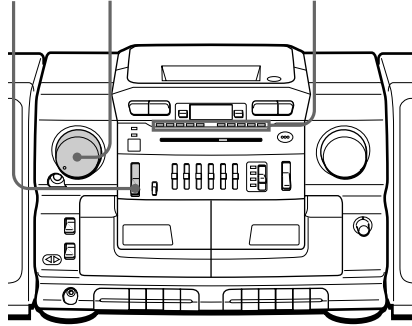

Tips

- During operation, the level meter shows the frequency level of the sound. Adjusting the volume will not affect the level meter.
- If the FM broadcast is noisy, set ISS•FM MODE at the rear to "MONO". Radio will play in monaural.

To	Do this
adjust the volume	Turn VOLUME.
turn off the radio	Set FUNCTION to TAPE•CD/RADIO OFF.

To improve broadcast reception

Reorient the antenna for FM. Reorient the player itself for MW or LW. For SW, extend the antenna vertically.

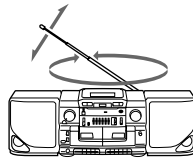

for FM

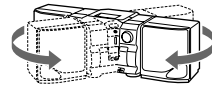

for MW/LW

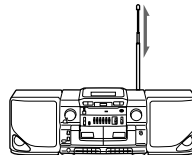

for SW

Playing a tape

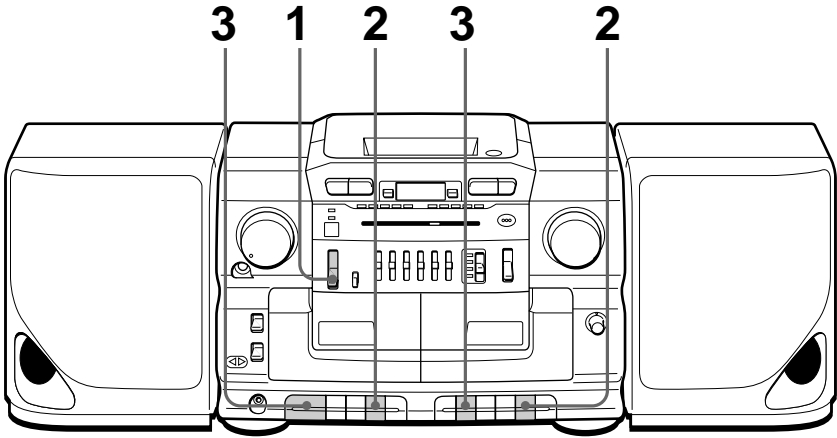

For hookup instructions, see pages 20 – 22.

1

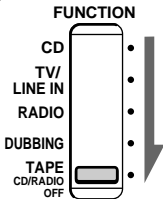

Set **FUNCTION** to **TAPED CD/RADIO OFF**.

2

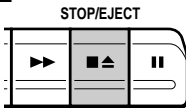

Press **■▲** to open tape compartment and insert a recorded tape. Use **TYPE I** (normal) tape only. Close the compartment.

With the side you want to play facing you

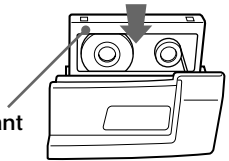

3

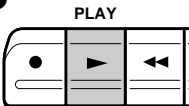

Press **▶**.
The player starts playing.

Use these buttons for additional operations

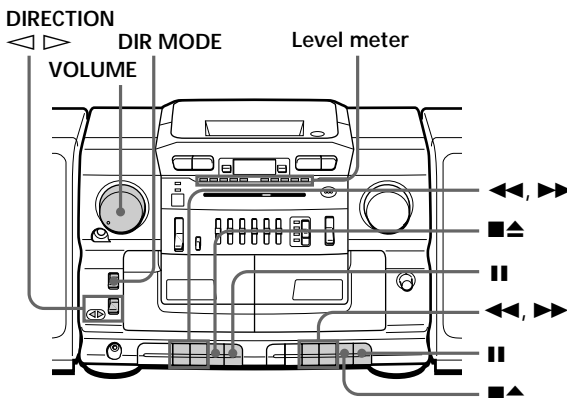

Note



During playback, do not press **▶▶**, **◀◀** or **▶** on the other deck as this causes excessive wow and flutter.

Tips

- During operation, the level meter shows the frequency level of the sound. Adjusting the volume will not affect the level meter.
- To play tapes in both decks successively, press **▶** on deck B and then press **PLAY** and **||** on deck A as the same time. When the tape ends on deck B, the playback starts automatically on deck A.

To	Do this
adjust the volume	Turn VOLUME .
stop playback	Press ■▶
fast-forward or rewind the tape	Press ▶▶ or ◀◀ .
pause playback	Press Press the button again to resume play after pause.
play the opposite side of the tape (deck A only)	Press down DIRECTION once. DIRECTION ◀▶ (reverse/forward) indicators show the tape direction of deck A.
eject the cassette	Press ■▶

To select the direction of the tape (deck A only)

To play	Set DIR MODE to
both sides of the tape repeatedly	
both sides of the tape from the front side to reverse side only*	

* If play begins from the reverse side, the tape stops at the end of that side.

Recording on a tape

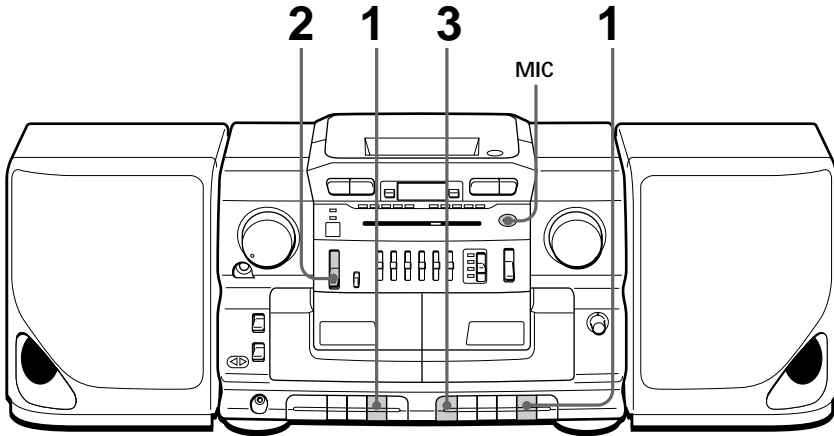

For hookup instructions, see pages 20 – 22.

1

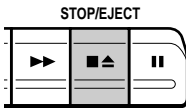

Press to open the tape compartment on deck B and insert a blank tape.

With the side you want to record on facing you

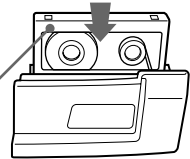

2

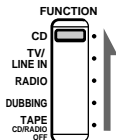

Select the program source you want to record.

Display

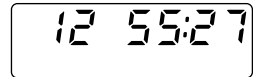

To record from the CD player, set FUNCTION to CD and insert a CD (see page 4).

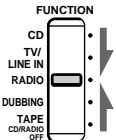

To record from the radio, set FUNCTION to RADIO, and tune in the station you want using BAND and TUNING (see page 6).

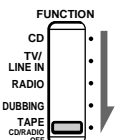

To record from the built-in microphone (MIC), set FUNCTION to TAPE • CD / RADIO OFF.

3

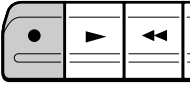
Deck B
REC

Start recording.

Press ● on deck B (▶ is depressed automatically).

Notes

- During recording, do not press ▶▶, ◀◀ or PLAY on deck A as this causes excessive wow and flutter.
- While recording from the built-in microphone (MIC), no sound comes from the speakers or the headphones.
- When you connect the microphone to the MIX MIC jack, you cannot record from the built-in microphone.

Tips

- Adjusting the volume or the audio emphasis (see page 24) will not affect the recording level.
- If the MW/LW program makes a whistling sound after you've pressed ● in step 3, set the ISS•FM MODE (Interference Suppress Switch) at the rear to the position that most decreases the noise.
- For the best results, use the AC power as a power source.

Use these buttons for additional operations

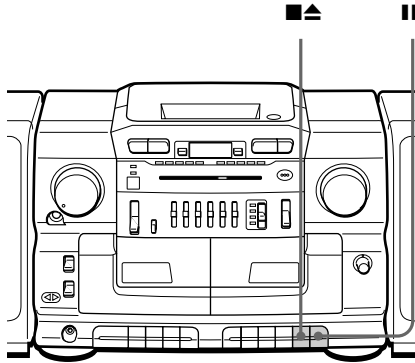

To	Press
Stop recording	■▲ on deck B
Pause recording	on deck B Press the button again to resume recording.

To erase a recording

- 1 Insert the tape into deck B.
- 2 Disconnect the audio source if connected to the TV/LINE IN jack at the rear.
- 3 Set FUNCTION to TV/LINE IN.
- 4 Press ● on deck B.

Dubbing

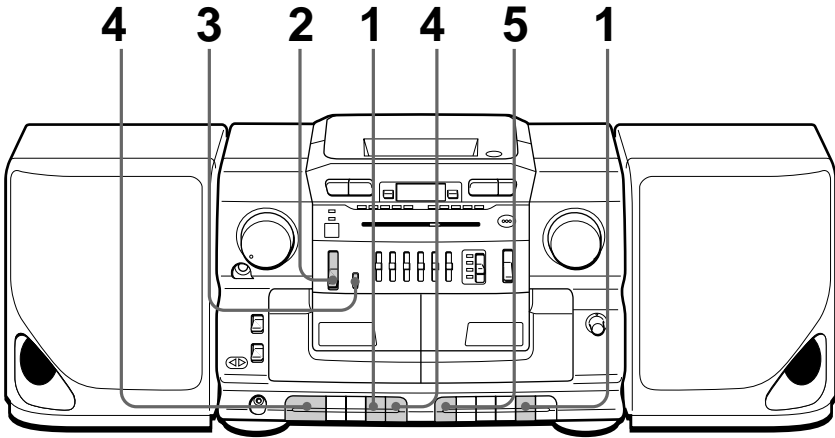

For hookup instructions, see pages 20 – 22.

1

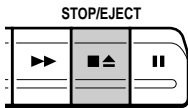

Insert a recorded tape into deck A and a blank tape into deck B.

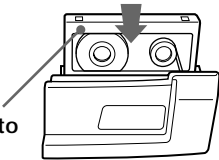

With the side you want to record on facing you

2

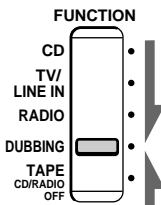

Set FUNCTION to DUBBING.

3

HIGH SPEED DUBBING

ON
OFF



To dub at high speed, press HIGH SPEED DUBBING to ON.

To dub at normal speed, press HIGH SPEED DUBBING to OFF.

4

Deck A

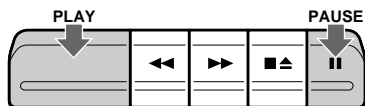
Press **||** and then press PLAY on deck A.

5

Deck B

Start dubbing.

Press ● on deck B (▶ is depressed automatically).

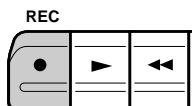
**Note**

During dubbing, do not set FUNCTION or press HIGH SPEED DUBBING as this causes excessive wow and flutter.

Tips

- Adjusting the volume or the audio emphasis (see page 24) will not affect the recording level.
- For the best results, use the AC power as a power source.
- When the tape in deck A ends first, deck B will continue recording till the tape end. When the tape in deck B ends first, deck A plays on according to the setting of the DIR MODE switch.

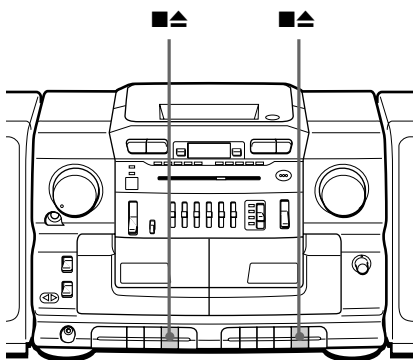
Use these buttons for additional operations**To stop dubbing**Press **■▲** on deck A and B.

Using the display

You can check information about the CD using the display.

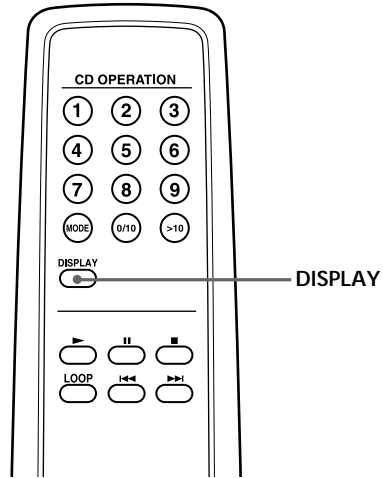

Checking the total track number and playing time

Check the display in stop mode.

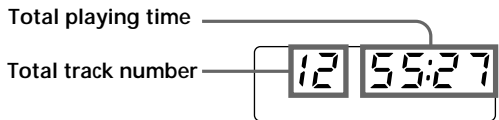

Checking the remaining time

Press DISPLAY (DISPLAY/ENTER on the player) while playing a CD.

To display	Press DISPLAY
remaining time on the current track*	once
remaining time on the CD and the number of tracks left	twice
playing time and the current track number	three times

* For a track whose number is more than 20, the remaining time appears as "--:--" in the display.

Locating a specific track

You can quickly locate any track using the number buttons. You can also find a specific point in a track while playing a CD.

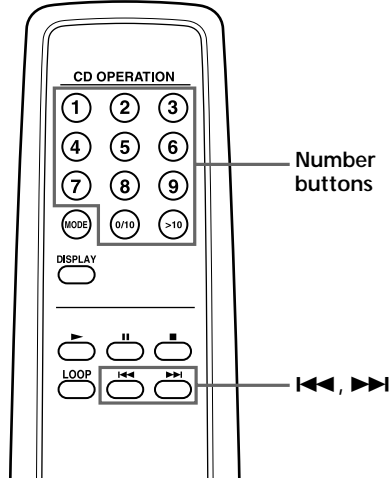

Note

You cannot locate a specific track if “SHUF REP” or “PGM” is lit in the display. Turn off the indication by pressing ■.

Tip

When you locate a track numbered over 10, press >10 first, then the corresponding number buttons.

Example:

To play track number 23, press >10 first, then 2 and 3.

To locate	Press
a specific track directly	the number button of the track.
a point while listening to the sound	▶▶I (forward) or I◀◀ (backward) while playing and hold down until you find the point.
a point while observing the display	▶▶I (forward) or I◀◀ (backward) in pause and hold down until you find the point.

Playing tracks repeatedly

(Repeat Play)

You can play tracks repeatedly in normal, shuffle or program play modes (see page 17).

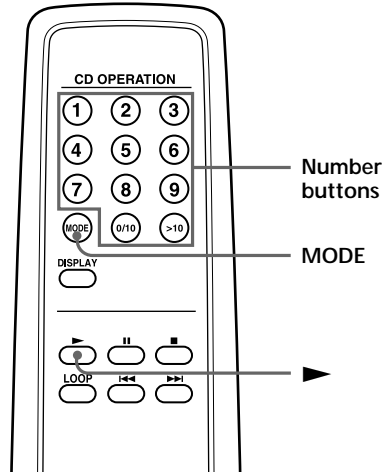

Tip

Press and hold LOOP on the remote during play to repeat a selected part of a CD. When you release LOOP, the player returns to normal play.

- 1 Set FUNCTION to CD on the player.
- 2 Press MODE (PLAY MODE on the player) until the repeat mode you want appears in the display.

To repeat	Select
asingletrack	REP 1
allthetracks	REP ALL
tracksinrandomorder	SHUF REP
programedtracks	PGM REP

- 3 Do either of the following to start repeat play:
 - When you've selected REP 1, select the track by pressing the number button (pressing ◀◀ or ▶▶ then ▶|| on the player).
 - When you've selected REP ALL or SHUF REP, press ▶ (▶|| on the player).
 - When you've selected PGM REP, program tracks (see step 3 on page 17), then press ▶ (▶|| on the player).

To cancel Repeat Play

Press MODE until "REP" disappears from the display.

Creating your own program

(Program Play)

You can arrange the playing order of up to 20 tracks on a CD.

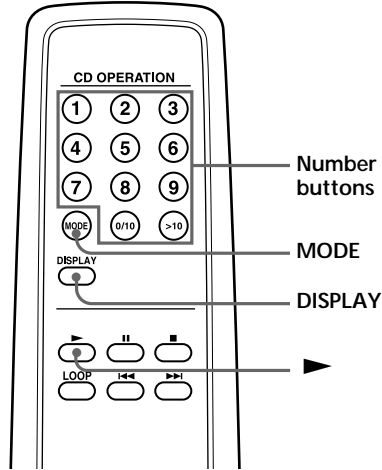

On the player

- 1 Set FUNCTION to CD.
- 2 Press PLAY MODE until "PGM" appears in the display.
- 3 Press ◀◀ or ▶▶ then press DISPLAY/ENTER for the tracks you want to program in the order you want.
- 4 Press ▶▶.

- 1 Set FUNCTION to CD on the player.
- 2 Press MODE until "PGM" appears in the display.
- 3 Press the number buttons for the tracks you want to program in the order you want.

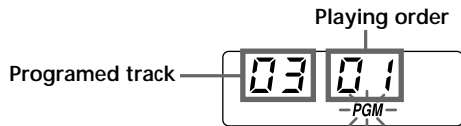

- 4 Press ▶▶ to start program play.

continued

Creating your own program (Program Play) (continued)

Tips

- You can play the same program again, since the program is saved until you open the CD compartment or switch FUNCTION.
- The current program will be erased if you switch FUNCTION or open the CD compartment.
- You can record your own program. After you've created the program, insert a blank tape into deck B and press ● on deck B to start recording.

To cancel Program Play

Press MODE until "PGM" disappears from the display.

To check the order of tracks before play

Press DISPLAY.

Every time you press the button, the track number appears in the programmed order.

To change the current program

Press ■ once if the CD is stopped and twice if the CD is playing. The current program will be erased. Then create a new program following the programming procedure.

Recording through a microphone/Using as a PA system

MIX MIC FUNCTION ●

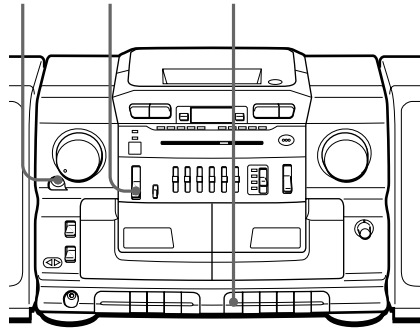

Recording through a microphone

- 1 Press the **MIX MIC** button.
- 2 Press the **RECORD** button.
- 3 Press the **STOP** button.

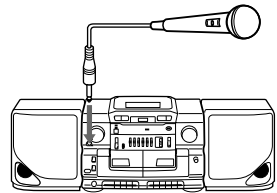

- 2 Press the **RECORD** button.
- 3 Press the **STOP** button.

Using as a PA system

- 1 Press the **MIX MIC** button.
- 2 Press the **RECORD** button.
- 3 Press the **STOP** button.

Hooking up the system

Make sure you turn off the power before making any connections.

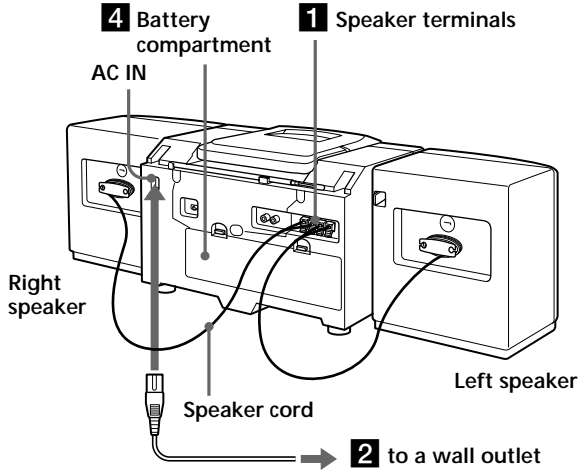

Tips

- To detach the speakers, unlock speaker (see B on the diagram) and slide the speaker box all the way up and away from the player.
- Connect the supplied speakers to this player. If you connect any other speakers or equipment, malfunction may occur.

1 Hooking up the speakers

- 1 Align the grooves and slide the speaker box down until it snaps into place A.

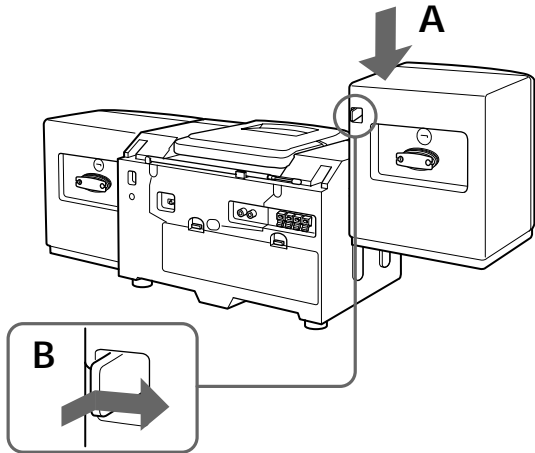

- 2** Connect the black wires to (-) minus and the red wires to (+) plus terminals; the right speaker wires to the R and the left speaker wires to the L terminals.

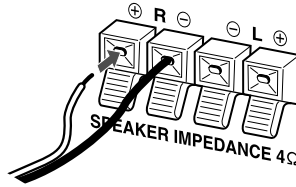

Tip

Only for the customers supplied with an AC plug adaptor:

Use the supplied AC plug adaptor if the plug of the AC power cord does not match your outlet.

2 Connecting the AC power cord

Insert one end of the supplied AC power cord to the AC IN socket located at the rear of the player, and the other end to the wall outlet.

CFD-CD777S only: Adjusting the voltage

Be sure to set the VOLTAGE SELECTOR (at the rear) to your local power supply.

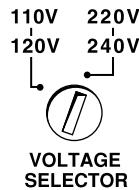

continued

Hooking up the system (continued)

3 Inserting batteries into the remote

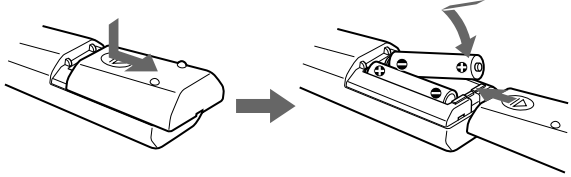

Insert two R6 (size AA) batteries (not supplied)

Replacing batteries

With normal use, the batteries should last for about six months. When the remote no longer operates the player, replace all the batteries with new ones.

Tip

Replace the batteries when the OPR/BATT indicator dims or when the player stops operating. Replace all the batteries with new ones. Before you replace the batteries, be sure to take out the CD from the player.

4 Using the player on batteries

Insert eight R20 (size D) batteries (not supplied) into the battery compartment.

To use the player on batteries, disconnect the AC power cord from the player.

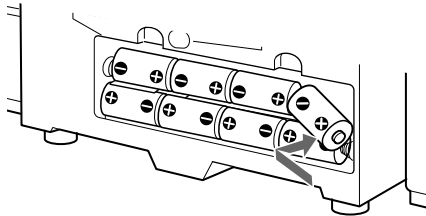

Connecting optional components

You can enjoy the sound from a TV or VCR through the speakers of this player.

For details, refer to the instruction manual of the component to be connected.

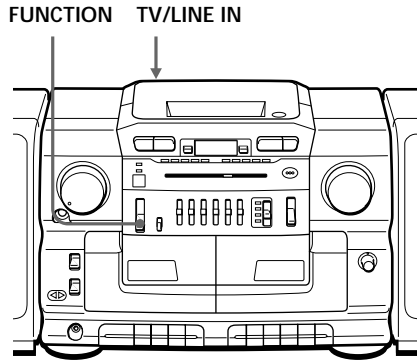

Note

Connect the cables firmly to avoid any malfunction.

Tip

You can record the sound of the connected component. Insert a blank tape, and press ● on deck B.

Before making connections, be sure to turn off the power of each equipment, and set FUNCTION to TAPE • CD/RADIO OFF.

- 1 Connect a component to the player.

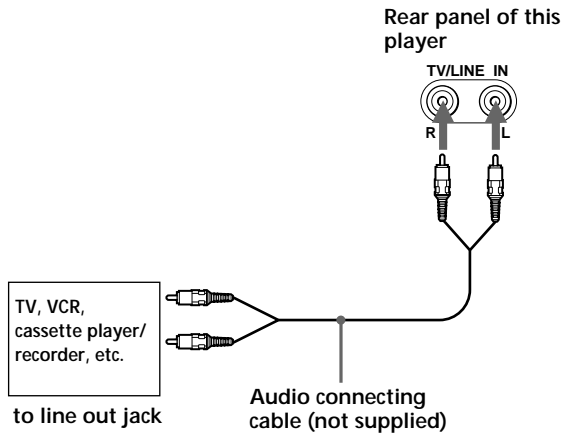

- 2 Set FUNCTION to TV/LINE IN and play the connected component.

Adjusting the audio emphasis (DYNAMIC SOUND SYSTEM)

You can adjust the audio emphasis of the sound you are listening to.

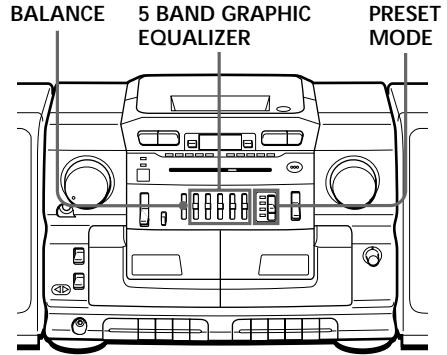

Note

When adjusting the 5 BAND GRAPHIC EQUALIZER, be sure to set the PRESET MODE selector to MANUAL. The graphic equalizer will not work in any other position.

Using the 5 BAND GRAPHIC EQUALIZER

Slide 5 BAND GRAPHIC EQUALIZER to select the audio emphasis you want.

Use	To adjust
MEGA BASS	deep bass sound
400 Hz	speaking voice, middle frequencies of instrumental music
1 kHz	presence of vocals
4 kHz	brightness of sound
10 kHz	high treble sounds or to reduce high frequency noise/tape hiss

Using the PRESET MODE

Set the PRESET MODE selector to the sound mode you want.

Use	To
MANUAL	adjust the sound using the 5 BAND GRAPHIC EQUALIZER.
DISCO	get powerful, clear sounds emphasizing low and high range audio.
PARTY	get light, bright sounds emphasizing high and middle range audio.
LIVE	get wide-ranging sounds having presence.

Adjusting the sound balance of the left and right speakers

Use BALANCE.

Precautions

On safety

- As the laser beam used in the CD player section is harmful to the eyes, do not attempt to disassemble the casing. Refer servicing to qualified personnel only.
- Should any solid object or liquid fall into the player, unplug the player, and have it checked by qualified personnel before operating it any further.

On power sources

- For AC operation, check that the player's operating voltage is identical with your local power supply (see "Specifications") and use the supplied AC power cord; do not use any other type. The voltage selector is located at the rear of the player (CFD-CD777S only).
- The player is not disconnected from the AC power source (mains) as long as it is connected to the wall outlet, even if the player itself has been turned off.
- For battery operation, use eight R20 (size D) batteries.
- When the batteries are not to be used, remove them to avoid damage that can be caused by battery leakage or corrosion.
- The nameplate indicating operating voltage, power consumption, etc. is located at the rear.

On placement

- Do not leave the player in a location near heat sources, or in a place subject to direct sunlight, excessive dust or mechanical shock.
- Do not place the player on an inclined or unstable place.
- Do not place anything within 10 mm of the side of the cabinet. The ventilation holes must be unobstructed for the player to operate properly and prolong the life of its components.
- If the player is left in a car parked in the sun, be sure to choose a location in the car where the player will not be subjected to the direct rays of the sun.
- Since a strong magnet is used for the speakers, keep personal credit cards using magnetic coding or spring-wound watches away from the player to prevent possible damage from the magnet.

On operation

- If the player is brought directly from a cold to a warm location, or is placed in a very damp room, moisture may condense on the lens inside the CD player section. Should this occur, the player will not operate properly. In this case, remove the CD and wait about an hour for the moisture to evaporate.
- If the player has not been used for a long time, set it in the playback mode to warm it up for a few minutes before inserting a cassette.

If you have any questions or problems concerning your player, please consult your nearest Sony dealer.

continued

Precautions (continued)

Notes on CDs

- Before playing, clean the CD with a cleaning cloth. Wipe the CD from the center out.



- Do not use solvents such as benzine, thinner, commercially available cleaners or anti-static spray intended for vinyl LPs.
- Do not expose the CD to direct sunlight or heat sources such as hot air ducts, nor leave it in a car parked in direct sunlight as there can be a considerable rise in temperature inside the car.
- Do not stick paper or sticker on the CD, nor scratch the surface of the CD.
- After playing, store the CD in its case.

If there is a scratch, dirt or fingerprints on the CD, it may cause tracking error.

Notes on cassettes

- Break off the cassette tab from side A or B to prevent accidental recording. If you want to reuse the tape for recording, cover the broken tab with adhesive tape.

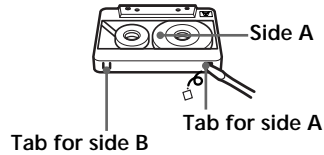

- The use of a cassette with more than 90 minutes of play time is not recommended except for long, continuous recording or playback.

Troubleshooting

	Symptom	Remedy
General	The power is not on.	<ul style="list-style-type: none"> • Connect the AC power cord to a wall outlet securely. • Make sure the batteries are inserted correctly.
	There is no audio.	<ul style="list-style-type: none"> • Set FUNCTION to the position you want to operate. • Adjust the volume. • Unplug the headphones when listening through speakers.
	“no disc” lights in the display even when a CD is in place.	<ul style="list-style-type: none"> • Insert the CD with the label surface up.
CD Player	The CD does not play.	<ul style="list-style-type: none"> • Make sure that the CD compartment is closed. • Place the CD with the label surface up. • Clean the CD. • Take out the CD and leave the CD compartment open for about an hour to dry moisture condensation. • Set FUNCTION to CD.
	The sound drops out.	<ul style="list-style-type: none"> • Reduce the volume. • Clean the CD, or replace it if the CD is badly damaged • Place the player in a location free from vibration.
	The audio is weak or has poor quality.	<ul style="list-style-type: none"> • Replace all the batteries with new ones if they are weak. • Move the player away from the TV. • If you are using the remote while listening to MW/LW radio, noise may be heard. This is unavoidable.
Radio	The picture of your TV becomes unstable.	<ul style="list-style-type: none"> • If you are listening to an FM program near the TV with an indoor antenna, move the player away from the TV.

continued

Troubleshooting (continued)

	Symptom	Remedy
Tape Player	The tape does not move when you press an operation button.	<ul style="list-style-type: none"> • Close the tape compartment securely.
	The REC ● button does not function/The tape does not play.	<ul style="list-style-type: none"> • Make sure the safety tab on the cassette is in place. • Make sure FUNCTION is set to "TAPE" or "DUBBING".
	The tape does not erase completely.	<ul style="list-style-type: none"> • Clean the erasing head (see page 29.) • Replace all the batteries with new ones if they are weak.
	The tape does not record.	<ul style="list-style-type: none"> • Make sure the tape is inserted properly. • Make sure the safety tab of the cassette is in place.
	The audio is weak/The audio quality is poor.	<ul style="list-style-type: none"> • Clean the heads, pinch rollers and capstans (See page 29). • Demagnetize the heads using a demagnetizer (see page 29).
Remote	The sound is distorted.	<ul style="list-style-type: none"> • The TYPE II (high position) or TYPE IV (metal) tape is being used. Use TYPE I (normal) tape only.
	The remote does not function.	<ul style="list-style-type: none"> • Replace all the batteries in the remote with new ones if they are weak. • Make sure that you are pointing the remote at the remote sensor on the player. • Remove any obstacles in the path of the remote and the player. • Make sure the remote sensor is not exposed to strong light such as direct sunlight or fluorescent lamp light. • Move closer to the player when using the remote.

After trying the above remedies, if the player still does not function properly, unplug the AC power cord and remove all the batteries. After all the indications in the display disappear, plug the power cord and insert the batteries again. If the problem persists, please consult your nearest Sony dealer.

Maintenance

Cleaning the lens

If the lens becomes dirty, it may cause a skipping of sound during CD operation. Clean with a commercially available blower.

Cleaning the tape heads and tape path

Wipe the heads, the pinch rollers and the capstans with a cleaning swab slightly moistened with cleaning fluid or alcohol after every 10 hours of operation for optimum playback and recording quality. To make the best possible recording, however, we recommend that you clean all surfaces over which tape travels before each recording.

Deck A

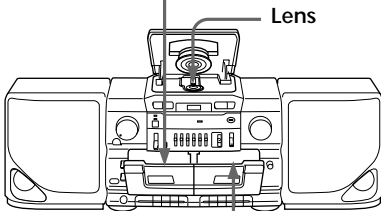
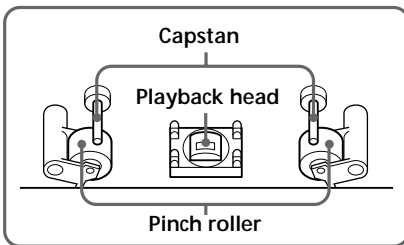

Deck B

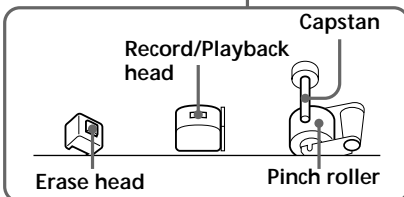

After cleaning, insert a tape when the areas cleaned are completely dry.

Demagnetizing the tape heads

After 20 to 30 hours of use, enough residual magnetism will have built up on the tape heads to begin to cause loss of high frequency sound and hiss. At this time, you should demagnetize the heads and all metal parts in the tape path with a commercially available tape head demagnetizer.

Cleaning the cabinet

Clean the cabinet, panel and controls with a soft cloth slightly moistened with a mild detergent solution. Do not use any type of abrasive pad, scouring powder, or solvent, such as alcohol or benzene.

Specifications

CD player section

System

Compact disc digital audio system

Laser diode properties

Material: GaAlAs

Wave length: 780 nm

Emission duration: Continuous

Laser output: Less than 44.6 μ W

(This output is the value measured at a distance of about 200 mm from the objective lens surface on the optical pick-up block with 7 mm aperture.)

Spindle speed

200 r/min (rpm) to 500 r/min (rpm) (CLV)

Number of channels

2

Frequency response

20 - 20,000 Hz +0/-1.5 dB

Wow and flutter

Below measurable limit

Radio section

Frequency range

CFD-CD777S

FM Saudi arabia	87.6 - 107 MHz
Other countries	87.6 - 108 MHz

MW	530 - 1,605 kHz
----	-----------------

SW1	2.3 - 7 MHz
-----	-------------

SW2	7 - 22 MHz
-----	------------

CFD-CD777L

FM	65.0 - 108 MHz
----	----------------

MW	531 - 1,602 kHz
----	-----------------

LW	153 - 279 kHz
----	---------------

SW	5.95 - 18 MHz
----	---------------

IF

FM: 10.7 MHz

SW/MW/LW: 455 kHz

Antennas

FM/SW: Telescopic antenna

MW/LW: Built-in ferrite bar antenna

Cassette-corder section

Recording system

4-track 2 channel stereo

Fast winding time

Approx. 120 s (sec.) with Sony cassette C-60

Frequency response

TYPE I (normal): 80 - 12,500 Hz

General

Speaker

Woofer: 10 cm (4 in.) dia., 4 ohms, cone type (2)

Tweeter: 5 cm (2 in.) dia.,

Outputs

Headphones jack (stereo minijack)

For 16 - 68 ohms impedance headphones

Maximum power output

12 W + 12 W

Power requirements

For CD radio cassette-corder:

CFD-CD777S

110 - 120, 220 - 240 V AC selectable, 50/60 Hz

CFD-CD777L

230 V AC, 50 Hz

12 V DC, 8 R20 (size D) batteries

For remote control:

3 V DC, 2 R6 (size AA) batteries

Power consumption

AC 47 W

Battery life

For CD radio cassette-corder:

FM recording

Sony R20P: approx. 4 h

Sony alkaline LR20: approx. 9 h

Tape playback

Sony R20P: approx. 2 h

Sony alkaline LR20: approx. 4 h

CD playback

Sony R20P: approx. 1.5 h

Sony alkaline LR20: approx. 3 h

Dimensions

Approx. 761 × 245 × 258 mm
(w/h/d) (30 × 9 ¾ × 10 ¼ inches)
(incl. projecting parts)

Mass

Approx. 9.5 kg (20 lb. 15 oz) (incl. batteries)

Supplied accessory

AC power cord (1)
Remote control (1)

Design and specifications are subject to change without notice.

Optional accessories

Sony MDR headphone series

Index

A

Audio emphasis 24

B

BALANCE 24

Batteries

for player 22

for remote 22

C

CD player 14

Cleaning

cabinet 29

lens 29

tape heads and tape
path 29

Connecting

AC power cord 21

optional components 23

Creating your own program
17

D, E, F

Demagnetizing the tape
heads 29

Display 14

Dubbing 12

G, H

GRAPHIC EQUALIZER 24

I, J, K

Improving broadcast
reception 7

L

Listening to the radio 6

Locating a specific track 15

M, N, O

MEGA BASS 24

P, Q

PA system 19

Playing

a CD 4

a tape 8

tracks repeatedly 16

PRESET MODE 24

Program Play 17

Public address system

See PA system.

R

Recording

on a tape 10

Repeat Play 16

S

Selecting

audio emphasis 24

tracks 15

Setting up 20

T

Troubleshooting 27

U

Using

the display 14

V, W, X, Y, Z

VOLTAGE SELECTOR 21